

Client

Details:
HANDRAILS

Creation
-Design, Drafting & Consulting
www.creationdrafting.com
email: art@creationdrafting.com
Ph. 778-476-5799

ONE FOR LEFT SIDE OF STAIRS
AND ONE FOR RIGHT SIDE OF STAIRS

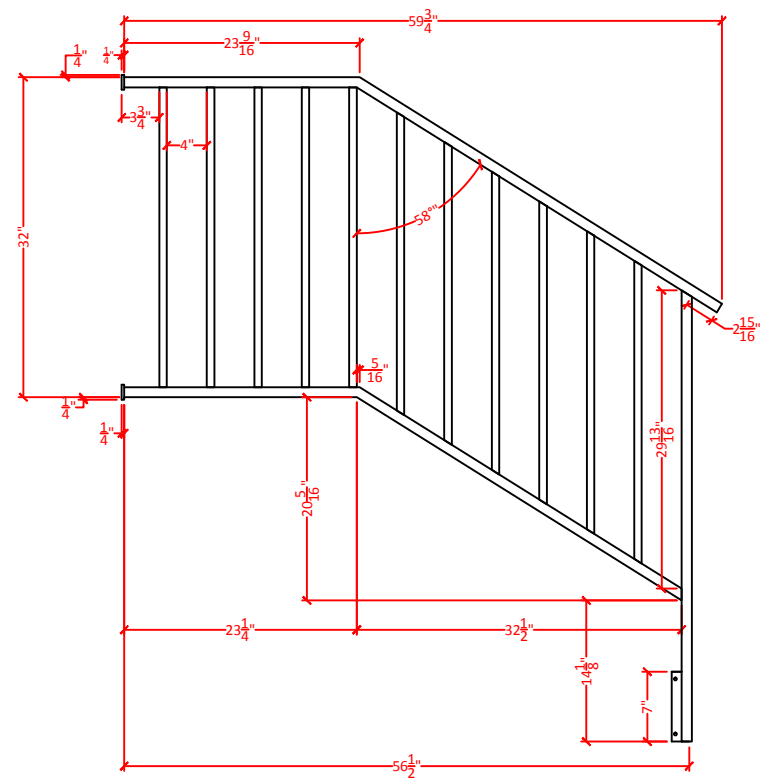
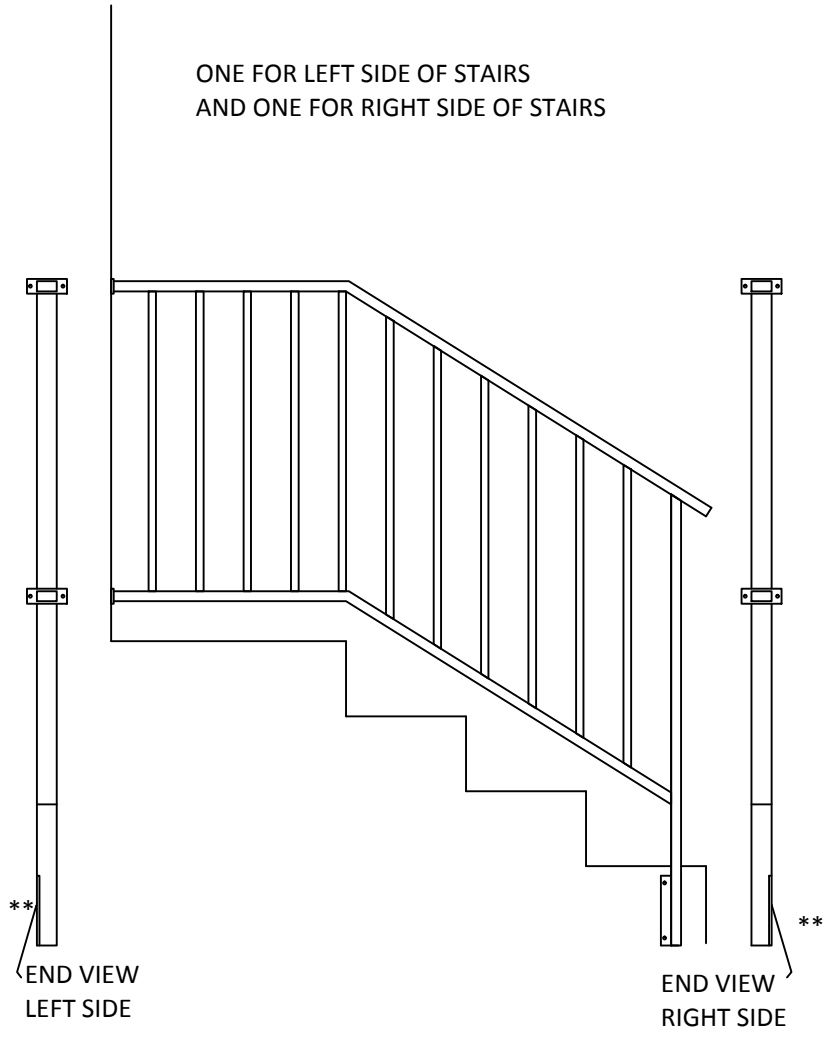

SCALE 5/8" = 1 FOOT

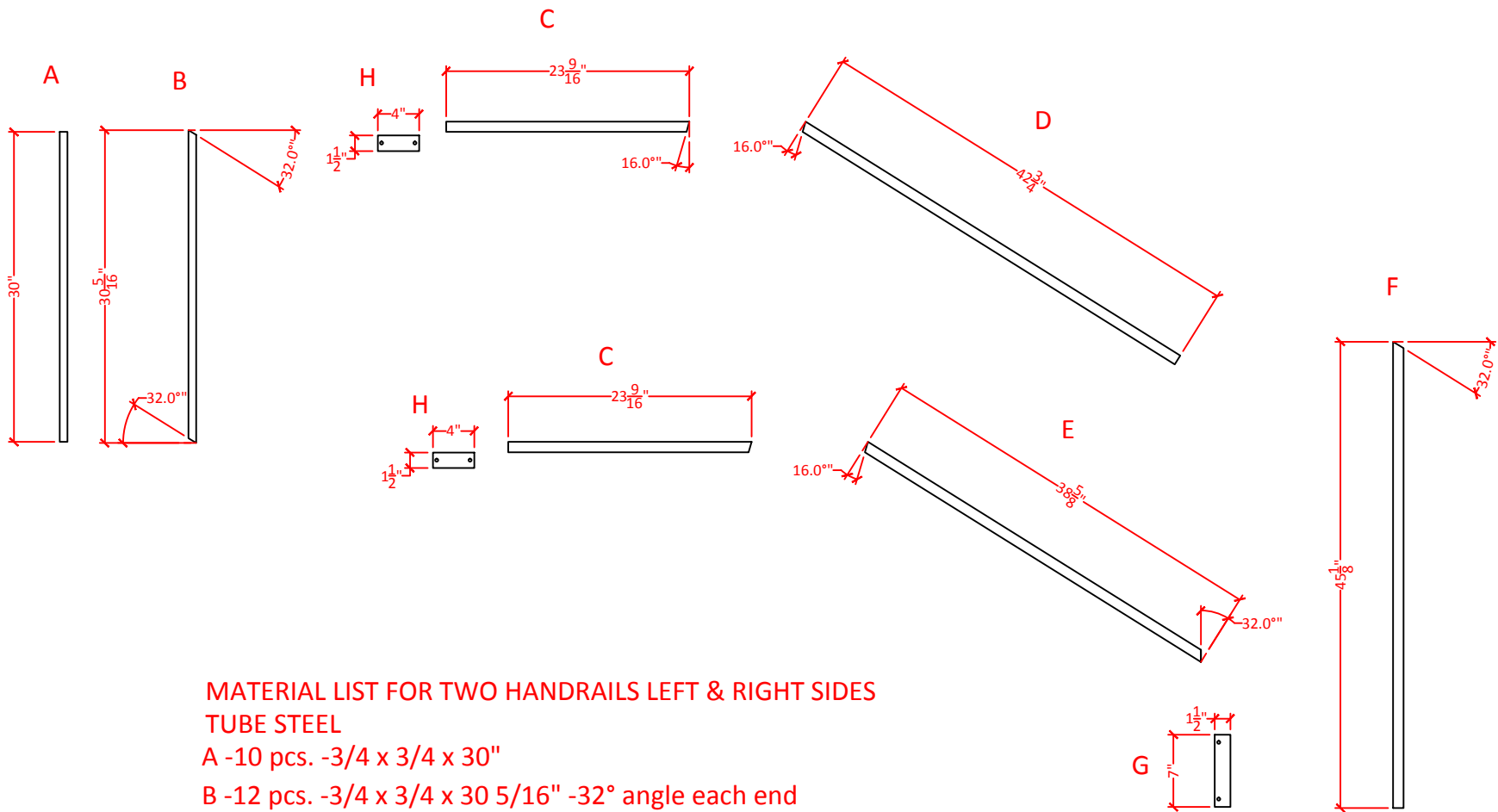

**MATERIAL LIST FOR TWO HANDRAILS LEFT & RIGHT SIDES
TUBE STEEL**

A -10 pcs. -3/4 x 3/4 x 30"

B -12 pcs. -3/4 x 3/4 x 30 5/16" -32° angle each end

C -4 pcs. -1" x 2" x 23 9/16" -16° angle one end

*D -2 pcs. -1" x 2" x 42 3/4" -16° angle one end

E -2 pcs. -1" x 2" x 38 5/8" -16° angle one end, 32° angle other end

F -2 pcs. -1" x 2" x 45 1/8" -32° angle other end

** G -2 pcs. -1/4" flat bar 1 1/2" x 7"

H -4 pcs. -1/4" flat bar 1 1/2" x 4"

* CAP SQUARE END OF THESE TWO RAILS

** TWO RAILINGS ARE IDENTICAL EXCEPT PART "G" (1/4" PLATE) IS
WELDED TO OPPOSITE FACES TO ALLOW MOUNTING TO EACH SIDE OF STAIRS

SCALE 1/2" = 1 FOOT

Page #	2		
Rev #	Date	28/11/2012	
Client	HANDRAILS		
Details:	HANDRAILS		
Creation	-Design, Drafting & Consulting www.creationdrafting.com email: art@creationdrafting.com Ph. 778-476-5799		