

PLANS AND SPECIFICATIONS

TABLE OF CONTENTS

TABLE OF CONTENTS	1
DOOR AND WINDOW SCHEDULE	1
FRONT ELEVATION	2
LEFT ELEVATION	2
RIGHT ELEVATION	3
REAR ELEVATION	3
CROSS SECTION DETAILS SECTION A	4
CROSS SECTION DETAILS SECTION B	4
FOUNDATION PLAN	5
MAIN FLOOR PLAN	6
LOWER FLOOR PLAN	7
MAIN FLOOR ELECTRICAL	8
LOWER FLOOR ELECTRICAL	9
ELEVATIONS	10
SITE PLOT PLAN	11

CUSTOM BUNGALOW WITH WALKOUT BASEMENT
 OWNER -BUILDER: ART & JOSHUA ISTD
 SQUARE FOOTAGE: 1152 SQ FEET
 LEGAL DESCRIPTION: 018-473-148, LOT 3
 DISTRICT LOT 373 SDYD PLAN KAP50870
 ADDRESS: 4469 MALLORY CRESENT
 OKANAGAN FALLS B.C.
 PLANS DESIGNED AND DRAWN BY ARTHUR ISTD
 PHONE: 778-476-5799

WINDOW SCHEDULE *all bedroom windows must meet code regulations						
Code	Qty	Glass size	Rough Opening	Description	Cost Each	Sub Total
				W X H		
W-1	3			2-0 X 5-0	FIXED/SLIDER	
W-2	1			3-6 X 5-0	FIXED	
W-3	1			3-0 X 5-0	FIXED/SLIDER	
W-4	1			5-0 X 4-0	FIXED	
W-5	2			4-0 X 3-0	FIXED/SLIDER	
W-6	1			2-0 X 2-6	FIXED/SLIDER	
W-7	1	OBSCURE GLASS		2-0 X 2-6	FIXED/SLIDER	
W-8	1			3-0 X 4-6	FIXED/SLIDER	
W-9	3			4-0 X 2-6	FIXED/SLIDER	
W-10	1			2-6 X 3-0	FIXED/SLIDER	
W-11	1			5-0 X 6-8	PATIO DOOR	
SUB TOTAL						
GST						
PST						
TOTAL						

DOOR SCHEDULE						
Code	Qty	Door Size	Rough Opening	Description	Cost Each	Sub Total
D-1	3	3-0 X 6-8		EXTERIOR LHH		
D-2	1	3-0 X 6-8		EXTERIOR RHH		
D-3	4	2-6 X 6-8		INTERIOR LHH		
D-4	5	2-6 X 6-8		INTERIOR RHH		
D-5	2	2-0 X 6-8		BIFOLD		
D-6	5	4-0 X 6-8		BIFOLD		
D-7	1	2-6 X 6-8		POCKET		
D-8	1	12-0 X 7-0		GARAGE		
SUB TOTAL						
GST						
PST						
TOTAL						

A-1	SHEET:	SCALE:	DATE: 04/10/2012	DRAWINGS PROVIDED BY: CREATION -Design, Drafting & Consulting	Art Istd email: art@creationdrafting.com website: creationdrafting.com phone: 778-476-5799	PROJECT DESCRIPTION: Mallory	<table border="1" style="width: 100%; border-collapse: collapse;"> <tr> <th>NO.</th> <th>DESCRIPTION</th> <th>BY</th> <th>DATE</th> </tr> <tr><td> </td><td> </td><td> </td><td> </td></tr> <tr><td> </td><td> </td><td> </td><td> </td></tr> <tr><td> </td><td> </td><td> </td><td> </td></tr> <tr><td> </td><td> </td><td> </td><td> </td></tr> </table>	NO.	DESCRIPTION	BY	DATE																
NO.	DESCRIPTION	BY	DATE																								

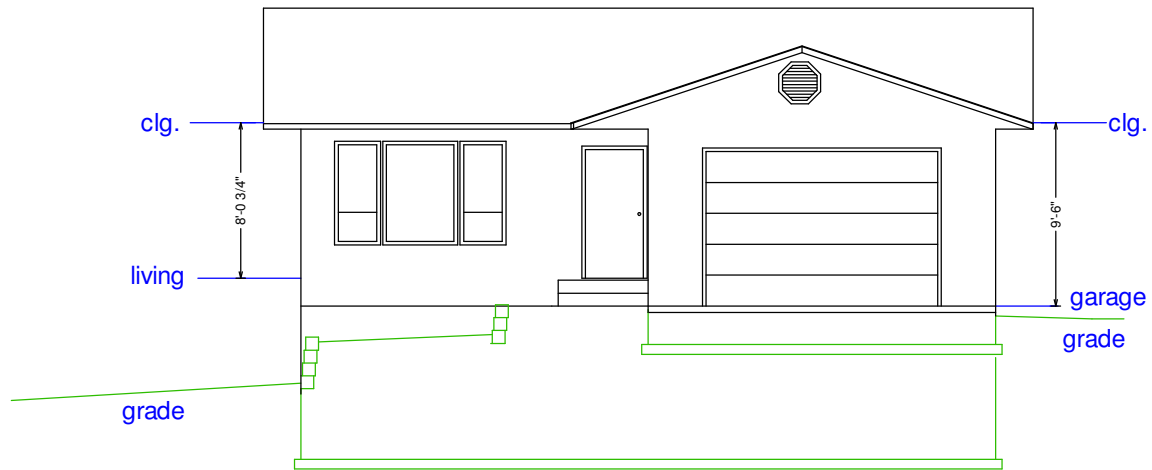

Front Elevation
Design by A. Isted

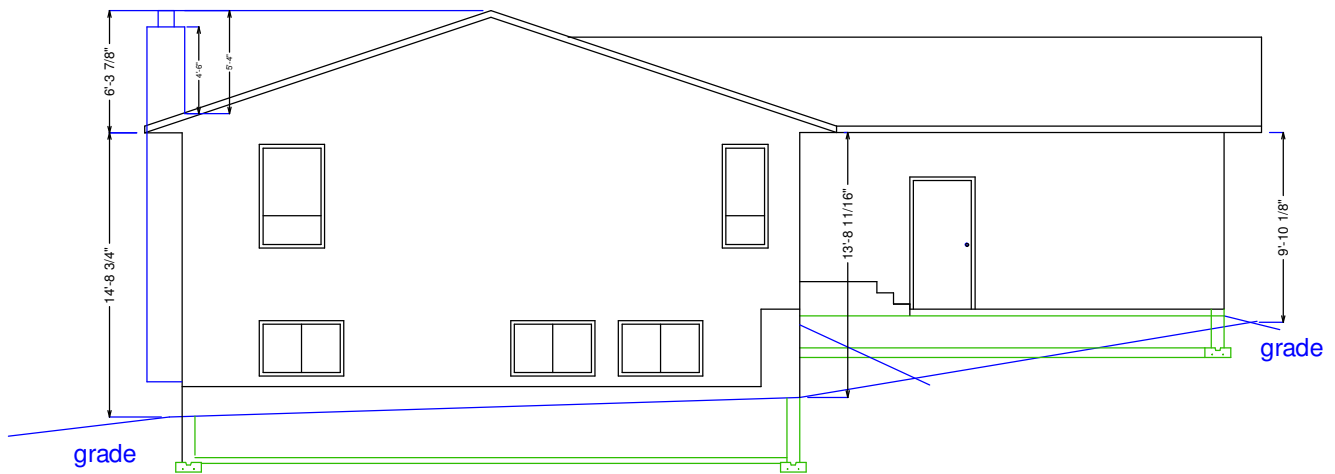

Left Elevation
Design by A. Isted

A-2

SHEET:

SCALE:

04/10/2012

DATE:

DRAWINGS PROVIDED BY:

CREATION
-Design, Drafting & Consulting

Art Isted
email: art@creationdrafting.com
website: creationdrafting.com
phone: 778-476-5799

PROJECT DESCRIPTION:

Mallory

NO.	DESCRIPTION	BY	DATE

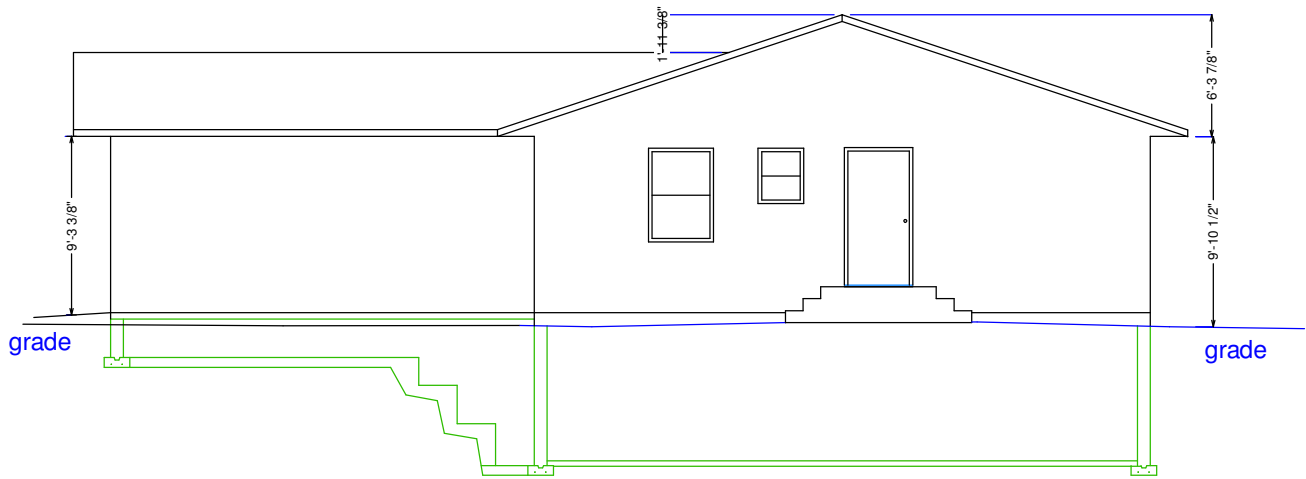

SCALE  Right Elevation
Design by A. Isted

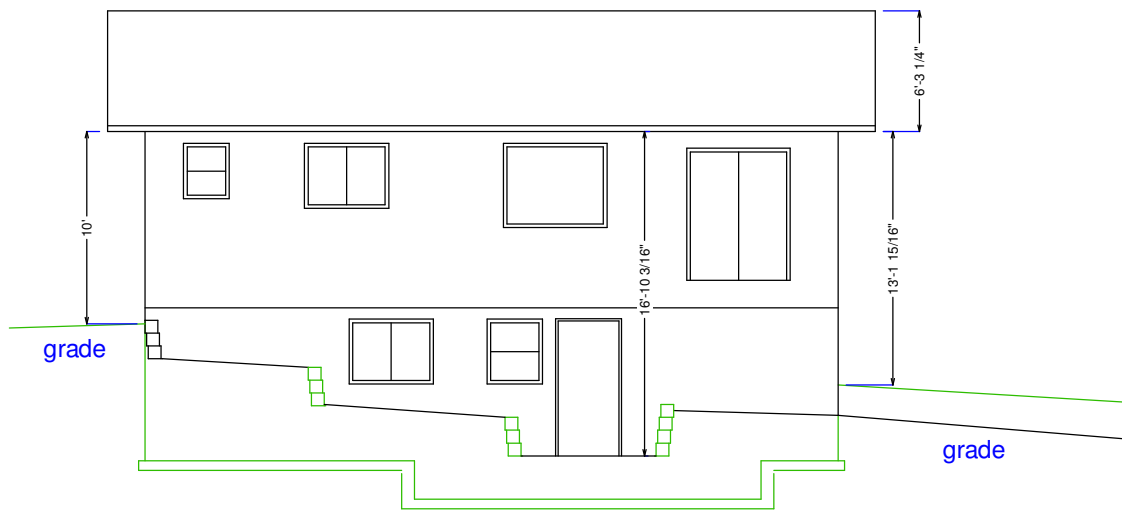

SCALE  Rear Elevation
Design by A. Isted

NO.	DESCRIPTION	BY	DATE

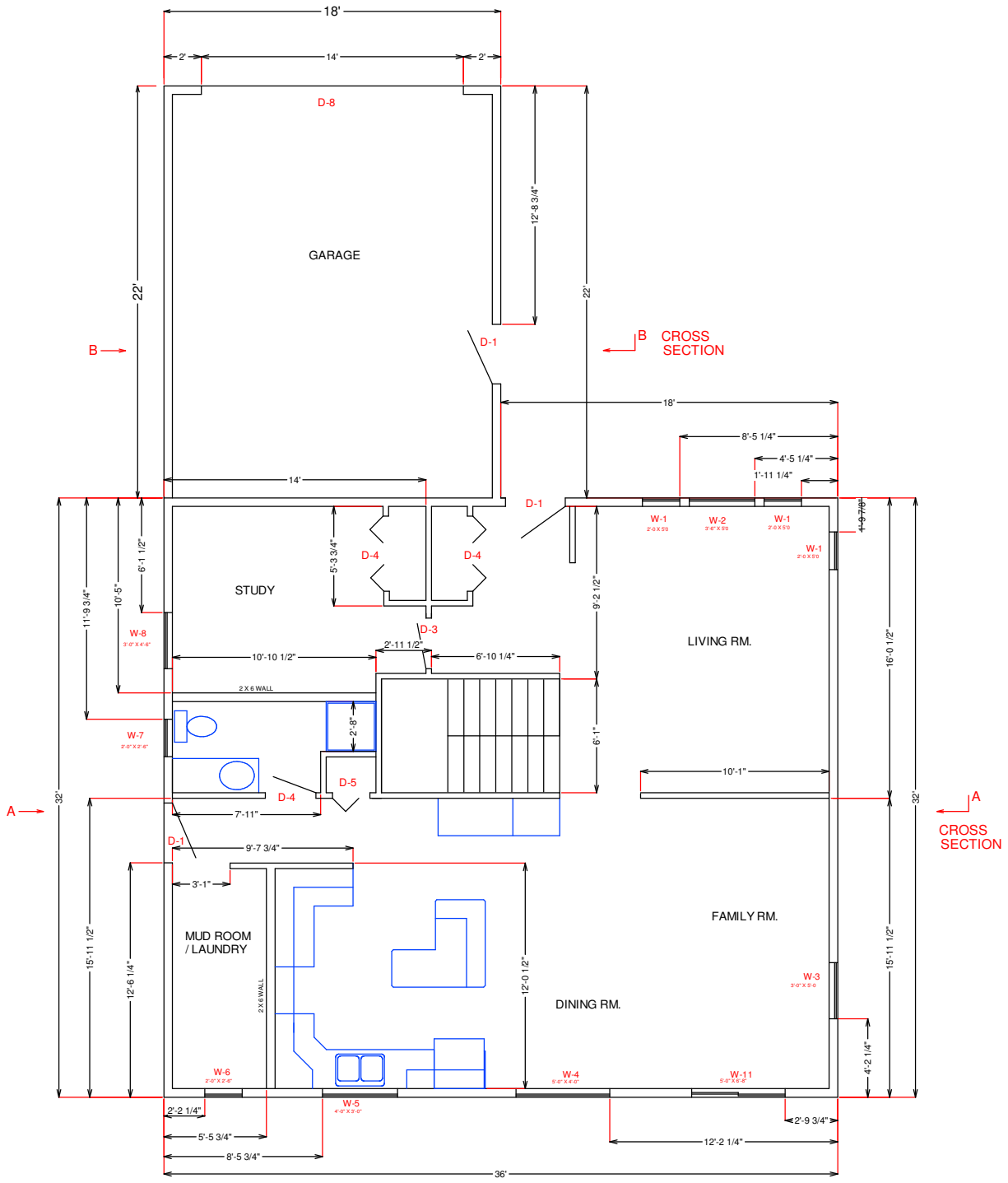

SCALE  MAIN FLOOR
Page 7
Design by A. Isted

A-5	SHEET:	SCALE:	DATE:	DRAWINGS PROVIDED BY:	Art Isted email: art@creationdrafting.com website: creationdrafting.com phone: 778-476-5799	PROJECT DESCRIPTION: Mallory	NO.	DESCRIPTION	BY	DATE
			04/10/2012	CREATION -Design, Drafting & Consulting						

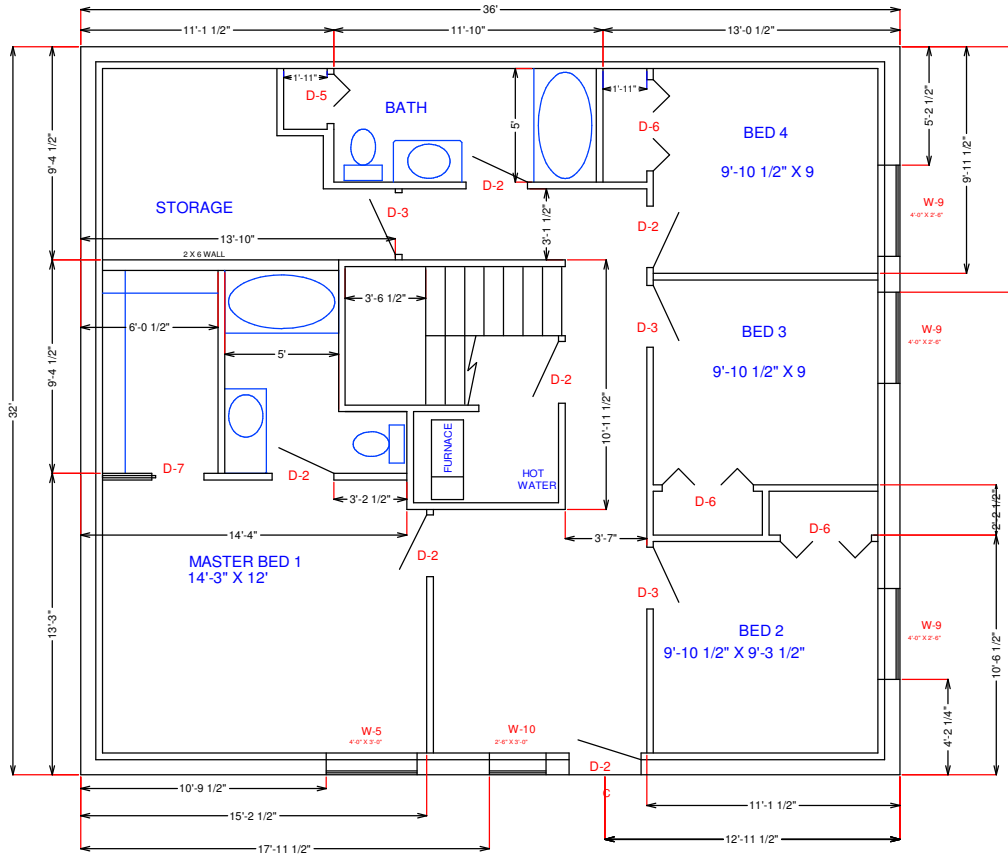

LOWER FLOOR PLAN
Design by A. Isted

A-6

SHEET:

SCALE:

DATE: 04/10/2012

DRAWINGS PROVIDED BY:

CREATION
-Design, Drafting & Consulting

Art Isted
email: art@creationdrafting.com
website: creationdrafting.com
phone: 778-476-5799

PROJECT DESCRIPTION:

Mallory

NO.	DESCRIPTION	BY	DATE

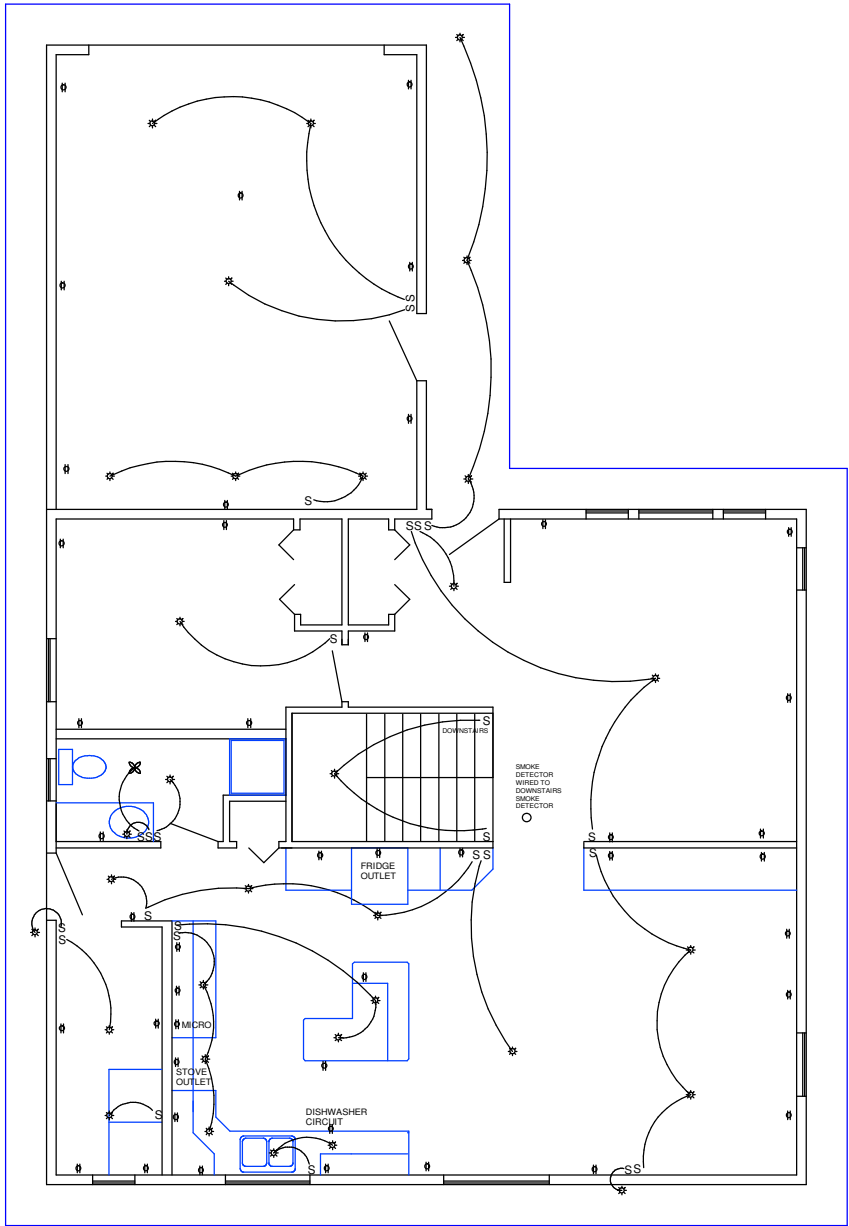

ELECTRICAL MAIN FLOOR
Design by A. Isted

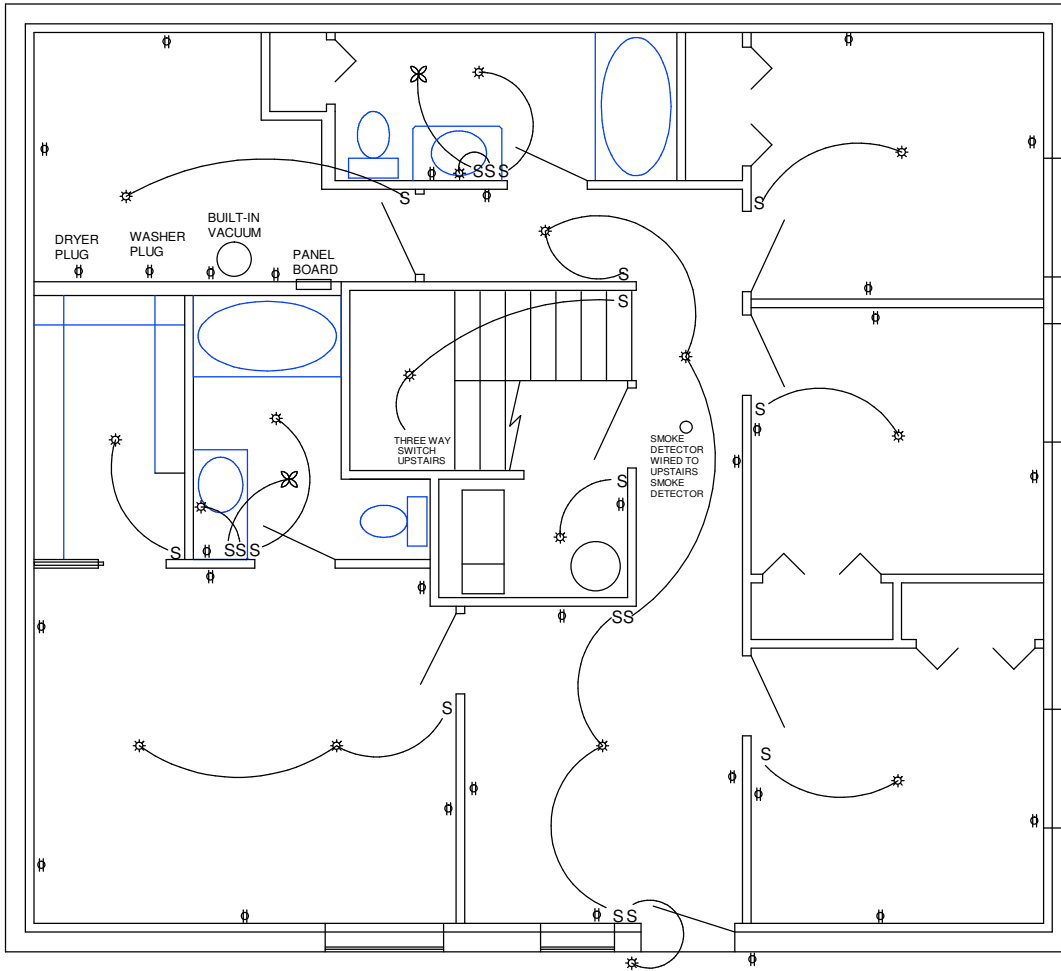

SCALE  ELECTRICAL LOWER
Design by A. Isted

A-8	SHEET:	SCALE:	DATE:	DRAWINGS PROVIDED BY:	Art Isted email: art@creationdrafting.com website: creationdrafting.com phone: 778-476-5799	PROJECT DESCRIPTION: Mallory	NO.	DESCRIPTION	BY	DATE
				CREATION -Design, Drafting & Consulting						

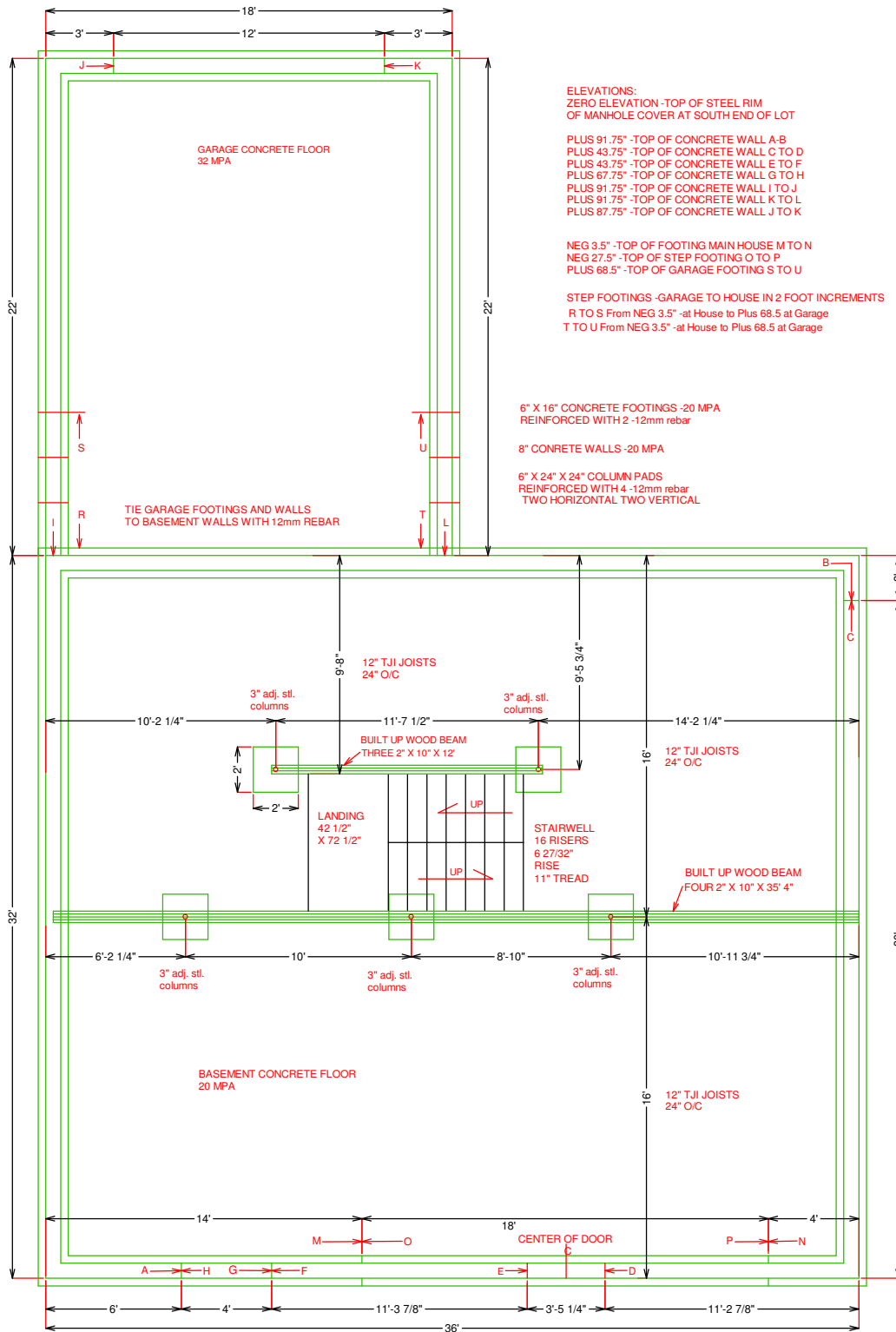

FOUNDATION
 Design by A. Isted

A-9

SHEET:

SCALE:

04/10/2012

DATE:

DRAWINGS PROVIDED BY:

CREATION
 -Design, Drafting & Consulting

Art Isted
 email: art@creationdrafting.com
 website: creationdrafting.com
 phone: 778-476-5799

PROJECT DESCRIPTION:

Mallory

NO.	DESCRIPTION	BY	DATE

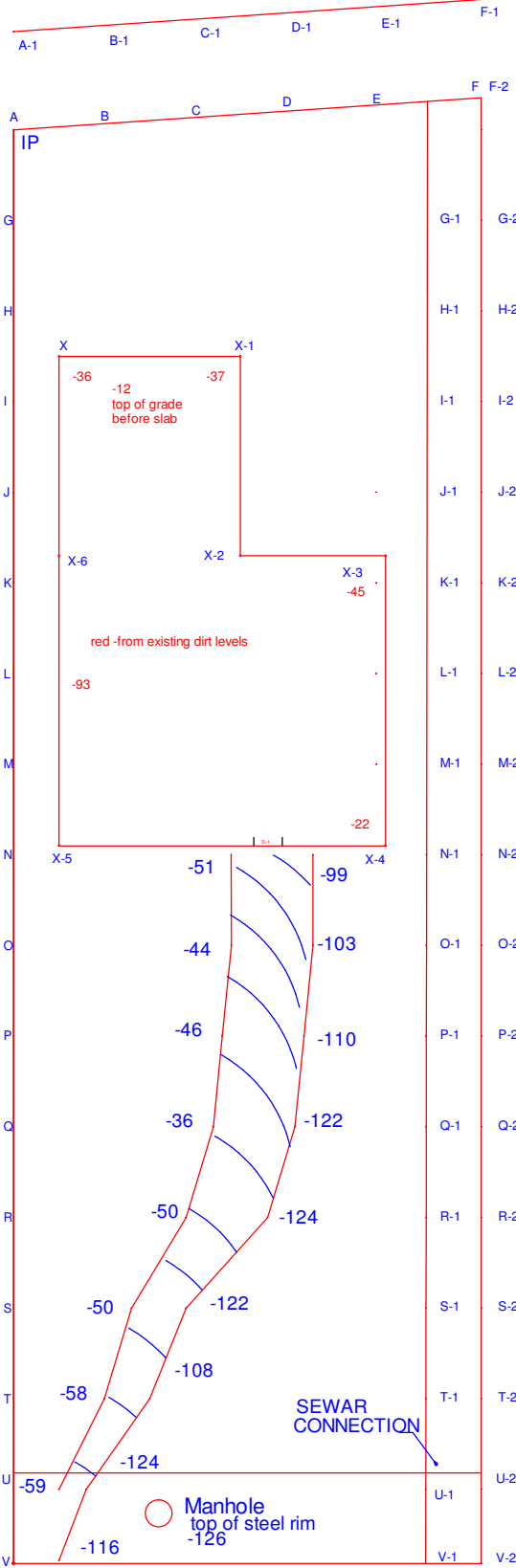

ALL DIMENSIONS ARE IN INCHES
0 POINT IS TOP OF IP NW CORNER

EXISTING LEVELS AT BUILDING CORNERS

- X=27
- X-1=-28
- X-2=-45
- X-3=-88
- X-4=-111
- X-5=-41
- X-6=-44

NORTH PROPERTY LINE

- A=0
- B=0
- C=14
- D=24
- E=35
- F=57 TOP OF NE IP
- F-2=-76 NEIGHBORS LOT -CUT DOWN

PLANNED BOTTOM OF FOOTINGS AT BUILDING CORNERS

- X=63.25
- X-1=63.25
- X-2=-134.5
- X-3=-134.5
- X-4=-134.5
- X-5=-134.5
- X-6=-134.5

EDGE OF ASPHALT MALLORY CRESENT

- A-1=15
- B-1=25
- C-1=35
- D-1=45
- E-1=55
- F-1=64

WEST PROPERTY LINE

- G=12
- H=19
- I=29
- J=40
- K=42
- L=40
- M=39
- N=42
- O=44
- P=46
- Q=36
- R=50
- S=58
- T=59
- U=80
- V=85

PLANNED FINAL GRADES AT BUILDING CORNERS

- X=34
- X-1=37
- X-2=30
- X-3=81
- X-4=100
- X-5=42
- X-6=42

EAST SIDE 5 TO 6 FEET WEST OF PROPERTY LINE

- G-1=51
- H-1=54
- I-1=60
- J-1=92
- K-1=92
- L-1=99
- M-1=106
- N-1=111
- O-1=115
- P-1=116
- Q-1=133
- R-1=151
- S-1=162
- T-1=173
- U-1=199
- V-1=217

EAST PROPERTY LINE -CUT AWAY BY NEIGHBORING DEVELOPMENT

- G-2=81
- H-2=83
- I-2=85
- J-2=94
- K-2=104
- L-2=109
- M-2=118
- N-2=125
- O-2=143
- P-2=149
- Q-2=161
- R-2=171
- S-2=187
- T-2=203
- U-2=213
- V-2=221



ELEVATIONS
Design by A. Isted

A-10	SHEET:	SCALE:	DATE: 04/10/2012	DRAWINGS PROVIDED BY: CREATION -Design, Drafting & Consulting	Art Isted email: art@creationdrafting.com website: creationdrafting.com phone: 778-476-5799	PROJECT DESCRIPTION: Mallory	<table border="1" style="width: 100%; border-collapse: collapse;"> <thead> <tr> <th>NO.</th> <th>DESCRIPTION</th> <th>BY</th> <th>DATE</th> </tr> </thead> <tbody> <tr><td> </td><td> </td><td> </td><td> </td></tr> <tr><td> </td><td> </td><td> </td><td> </td></tr> <tr><td> </td><td> </td><td> </td><td> </td></tr> <tr><td> </td><td> </td><td> </td><td> </td></tr> </tbody> </table>	NO.	DESCRIPTION	BY	DATE																
NO.	DESCRIPTION	BY	DATE																								

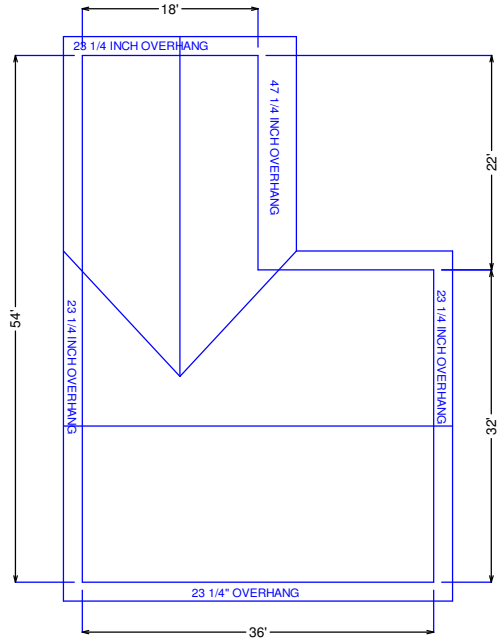
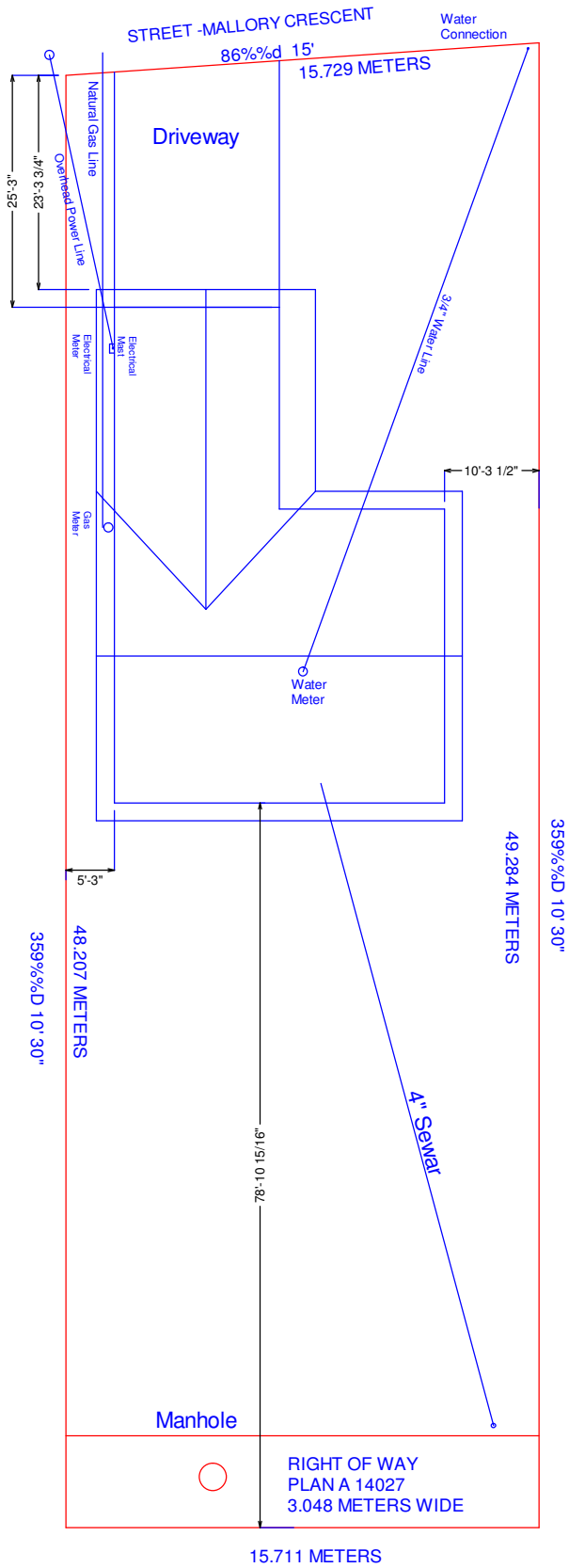

OVERALL DIMENSIONS OF STRUCTURE

LEGAL DESCRIPTION: 018-473-148, LOT 3
 DISTRICT LOT 373 SDYD PLAN KAP50870
 ADDRESS: 4469 MALLORY CRESENT
 OKANAGAN FALLS B.C.
 AREA 766 SQUARE METERS

RS1 Zoning
 SIDE 1.5 meters -4' 11 1/8"
 SIDE 3 meters -9' 10 1/8"
 FRONT 7.5 meters -24' 7 3/8"



Site Plan
 Design by A. Isted

A-11	SHEET:	SCALE:	DATE:	DRAWINGS PROVIDED BY:	Art Isted email: art@creationdrafting.com website: creationdrafting.com phone: 778-476-5799	PROJECT DESCRIPTION: Mallory	<table border="1"> <thead> <tr> <th>NO.</th> <th>DESCRIPTION</th> <th>BY</th> <th>DATE</th> </tr> </thead> <tbody> <tr><td> </td><td> </td><td> </td><td> </td></tr> <tr><td> </td><td> </td><td> </td><td> </td></tr> <tr><td> </td><td> </td><td> </td><td> </td></tr> <tr><td> </td><td> </td><td> </td><td> </td></tr> </tbody> </table>	NO.	DESCRIPTION	BY	DATE																
	NO.	DESCRIPTION	BY	DATE																							
04/10/2012	CREATION	-Design, Drafting & Consulting																									